

# Versa-Rail™

Model 60

Stairwell Safety Railing

**BPG**  
Byers Products Group

## INSTALLATION GUIDE

**ASSEMBLY &  
INSTALLATION**

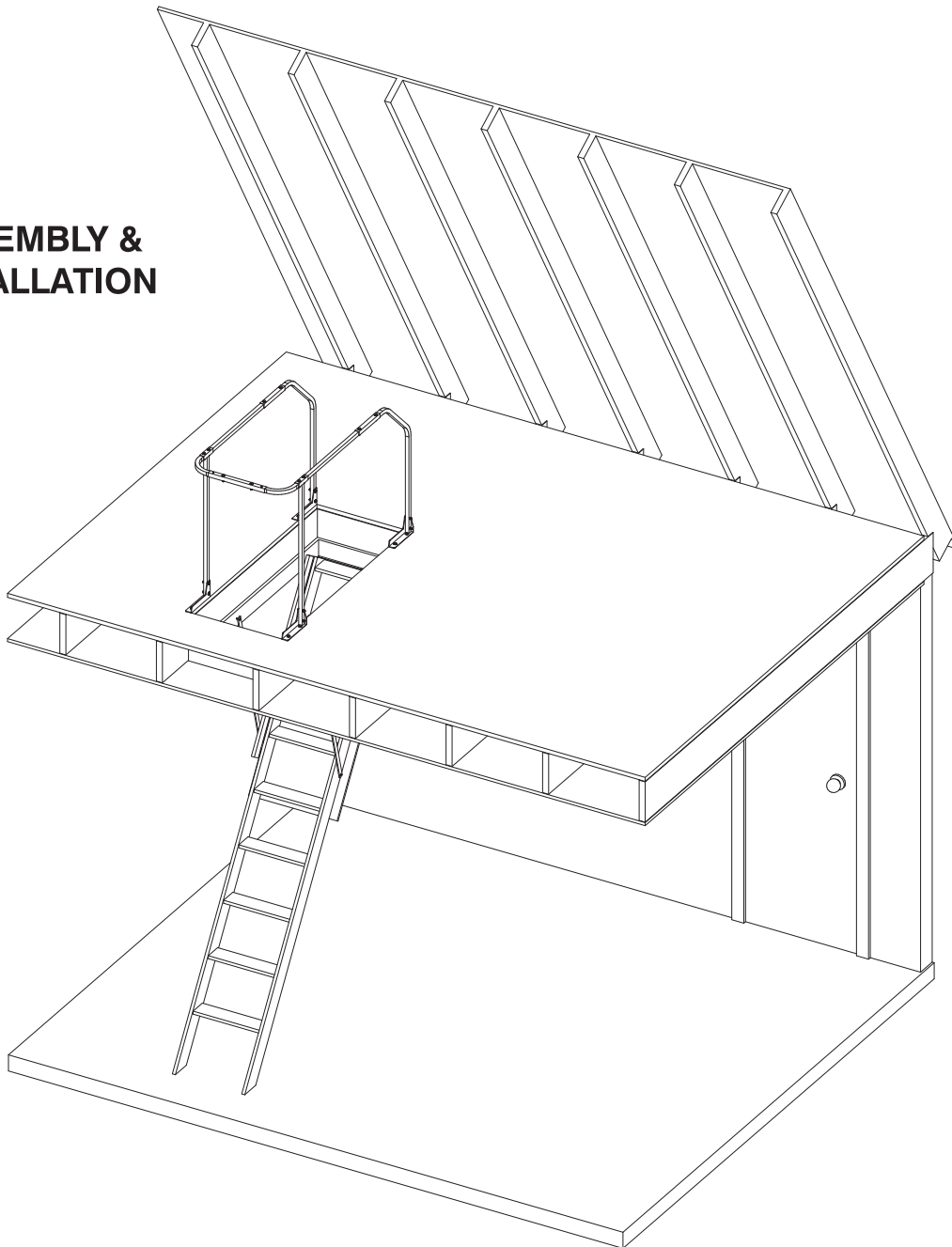

## Shipping Carton Contents:

Unpack your Versa-Rail shipping carton and locate all of the components pictured below and verify that you have the correct quantity of each part. If all parts are found, proceed to assembly. If any parts are not found, contact BPG for replacement (see page 4).

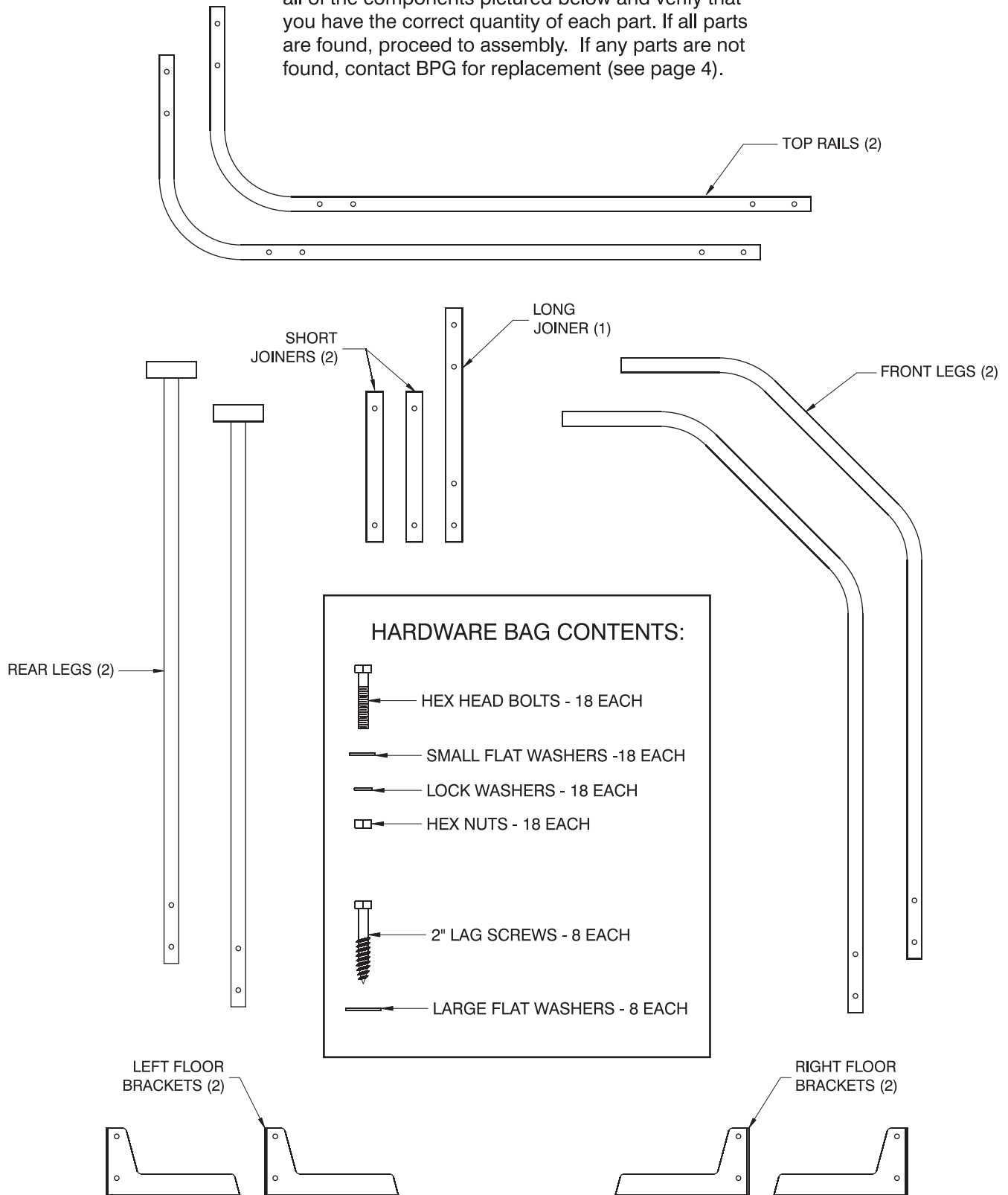

**ASSEMBLY & INSTALLATION:** It is recommended that you assemble the Versa-Rail in the attic. You will need wrenches to tighten bolts, a pencil to mark hole locations, and a drill with a 5/32" drill bit for making pilot holes for the lag screws.

1. Assemble the top rails into the long joiner. Adjust the hole positions to best fit your ladder opening width (Fig. 1). Install bolts, washers and nuts as shown, but do not tighten.
2. Assemble the rear legs onto the top rails (Fig. 2). Install bolts, washers and nuts as shown, but do not tighten.

3. Connect the front legs to the top rails with the short joiners. Adjust the hole positions to best fit your ladder opening length (Fig. 3). Install bolts, washers and nuts as shown, but do not tighten.

4. Install the left and right floor brackets onto the front and rear legs (Fig. 4). Orient the brackets exactly as shown. Install bolts, washers and nuts as shown, but do not tighten.
5. Place the rail assembly over the ladder opening. Align the brackets as shown and mark the hole locations (Fig. 5).

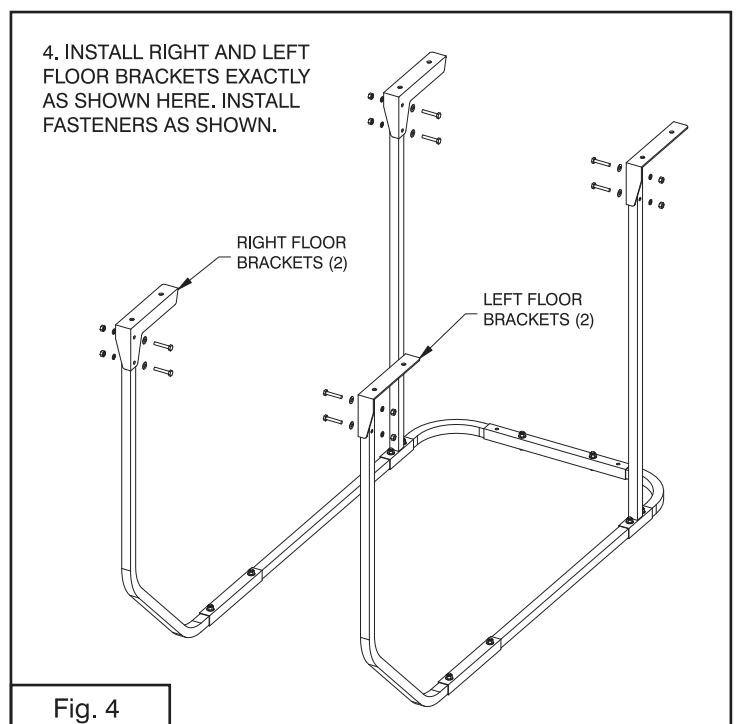
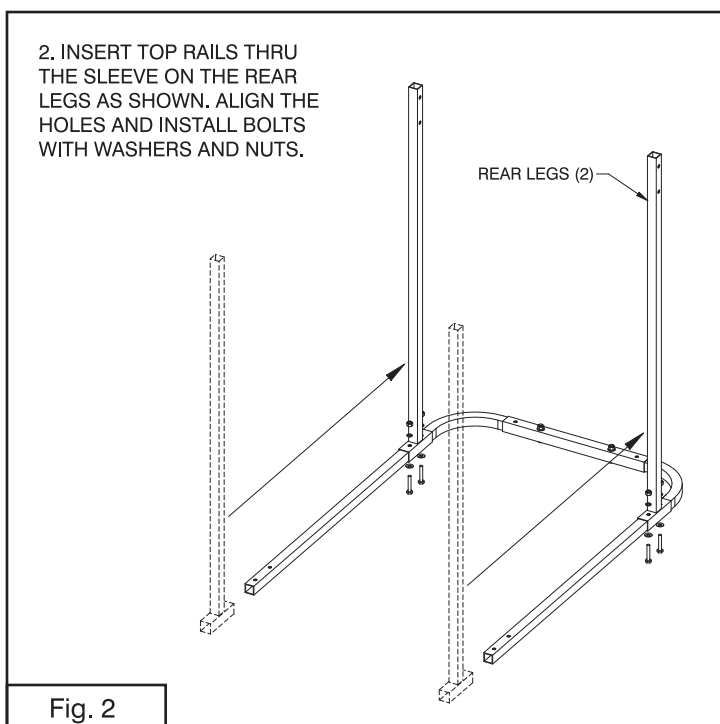
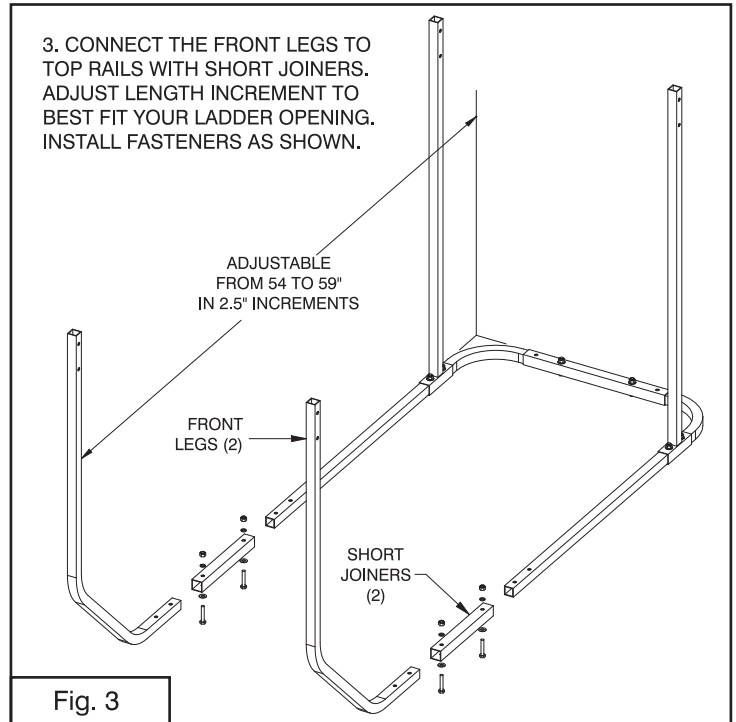
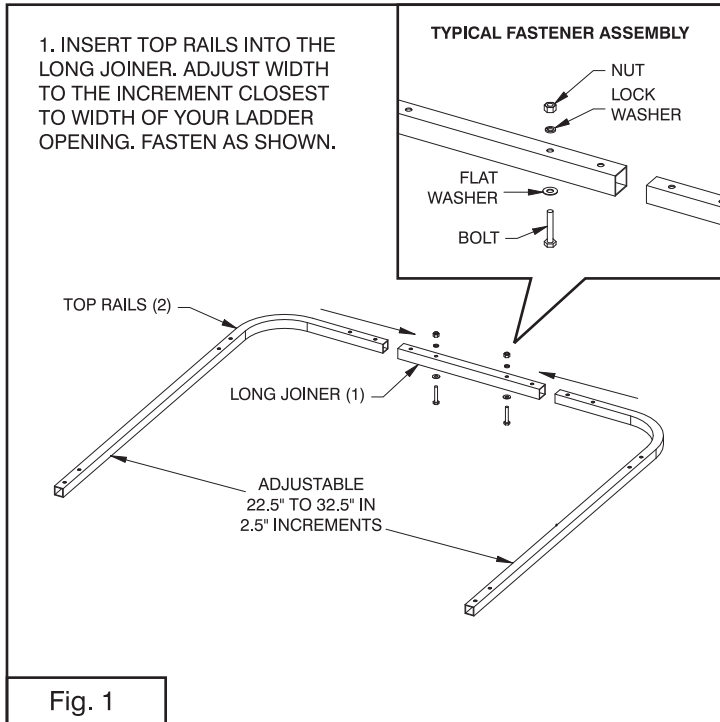

5. (cont.) Drill 5/32" pilot holes at each location x 2" deep.

6. Install the lag screws through the floor bracket and into the pilot holes (Fig. 6). Tighten firmly, do not over-tighten.

7. Now tighten all of the nuts and bolts used to assemble the Versa-Rail. Do not over-tighten or you will collapse the tubing walls. Congratulations, your installation is now completed. Your attic will now be a safer place to visit!

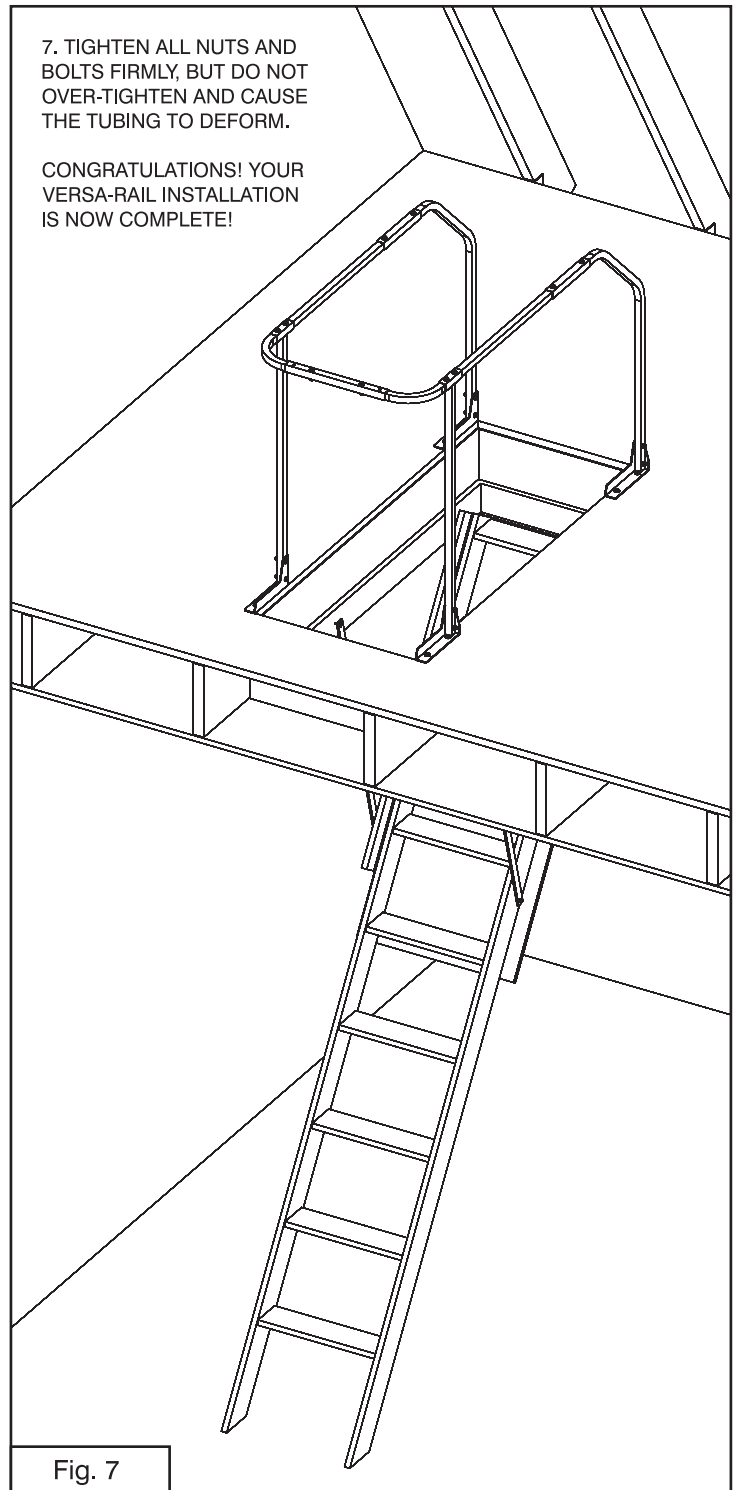
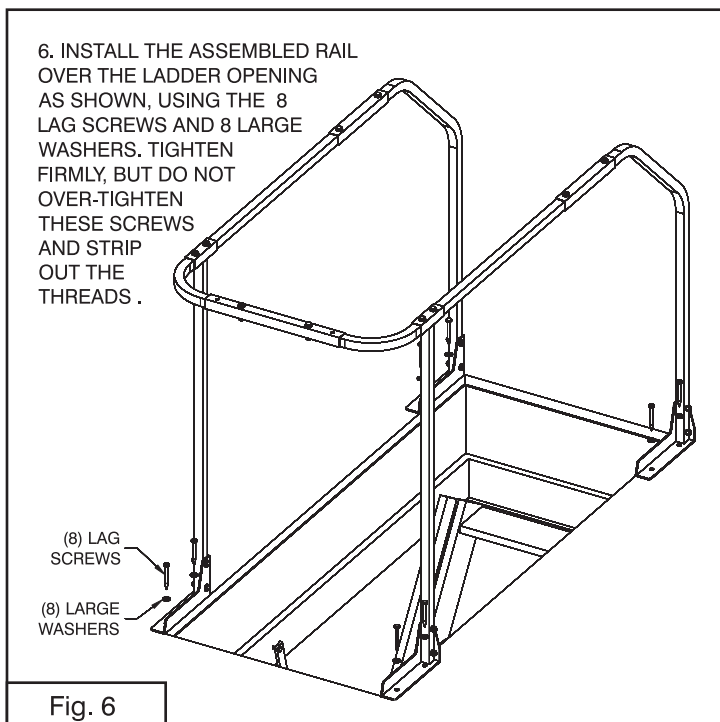
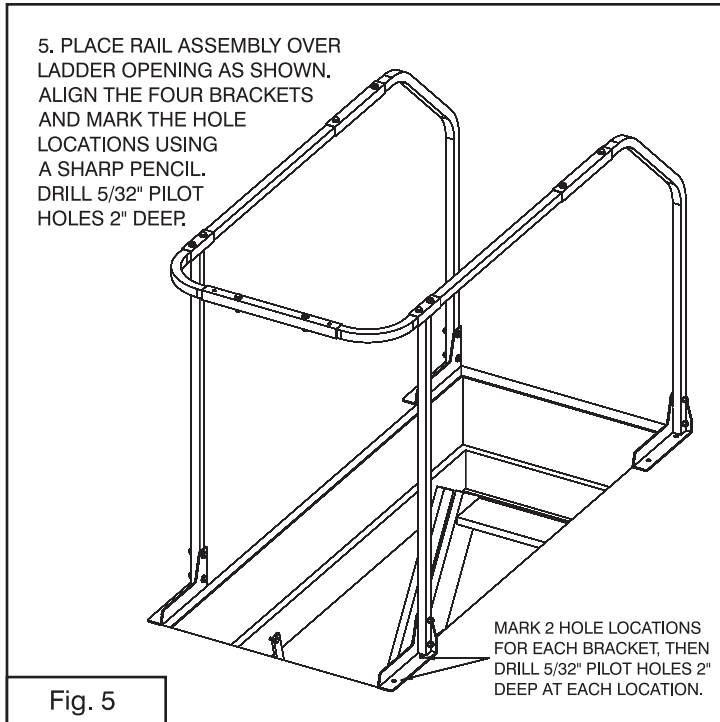

# BPG

Byers Products Group

P. O. Box 270366  
OKC City, OK 73137  
Ph: 405-943-1468  
Fax: 405-943-7577  
www.bpghome.com

"Innovations for your home"